



# Scissor COLT

## TRUCK SPECIFICATIONS

- Kenworth T370 6x4 Rated at 48,600-lb GVWR
- 8.9 Liter PX-9 330 HP 1,000 lb-ft Torque Turbo Diesel Engine
- 14,600-lb Front Axle with 14,600-lb Suspension
- 40,000-lb Rear Axle with 40,000-lb Walking Beam Suspension
- Allison 3500-RDS 6-Speed Automatic Transmission
- Dual Aluminum Fuel Tanks with 125 Gallon Total Capacity
- Premium Interior Including; Cruise, Tilt Steering, A/C, Power Windows
- AM/FM/CD with Bluetooth, Reverse Camera
- Air-Ride Suspended Driver's Seat and 2-Man Passenger Seat
- Aluminum Steps, Battery Box, Mirror Brackets and Air Tanks
- Integrated, Regulated Truck Battery Charger
- Road Spray Suppression Kits (Rear Axles)

## COLT SPECIFICATIONS & OPTIONS

### Bed Frame and Mounting Structure:

- Hot-Dipped Galvanized Steel Bed Frame
- (4) Stabilizing Outriggers with 7,000-lb Jacks
- Automatic Hydraulic Vehicle Leveling System
- RRU Mounting Framework for Mounting RRU and Multiplexers/Combiners
- Multi-Port Coax Bulkhead

### Mast:

- (2) 59' Pneumatic Ultra Heavy Duty Locking, 1,200-lb Lift Capacity Masts
- 2-Level 4-Way Guy Kit Included

### Generator:

- 45 kW Diesel Generator with Auto Start
- 1-Phase 120/240 Volt, 400/200 Amps
- 30-Hour Generator Runtime
- Integrated Block Heater and Battery Charger

### Sun West Engineering Scissor Lift:

- Severe Duty Hydraulic Scissor Lift Platform
- 1,000-lb Lifting Capacity
- Dual Hydraulically Actuated Lifting Cylinders
- 5-Stage Scissor Assembly with Guying Eyelets
- Rotatable Base Plate for Azimuth Control
- Extended Height – 38' at Center Line
- Powder Coated with Stainless Steel Hardware for Corrosion Protection
- Bio-degradable Vegetable Based Hydraulic Fluid
- 100% Containment Cabinet
- 2HP, 230V 60Hz, 1Ø Compressor Motor
- 1,500 PSI 1.82 GPM Hydraulic Pump
- 30-Gallon Hydraulic Fluid Reservoir

### 3-Bay Equipment Cabinet:

- U.L.® Listed NEMA 3R Communications Cabinet
- 200 AMP 40 Position 1-Phase 3-Wire Distribution Panel
- Automatic Transfer Switch with MOV/SAD Surge Protector and Cam Lock Connections
- (2) 3-Ton HVAC Units with Lead-Lag Controller
- 150 MPH Wind Load, 150-lb/sq. ft. Snow Load, 500-lb/sq. ft. Floor Load, Zone 4 Rated

### Options/Add-Ons:

- 60' 530-lb Capacity Mast in-lieu of 59' Mast
- 3-Sector Antenna Mounting System
- Pan & Tilt Microwave Mount with Controller
- Mid-Level Microwave Mount
- Multi-Position LED Work Lights
- Equipment Installation & Integration



SUN WEST  
ENGINEERING, INC.

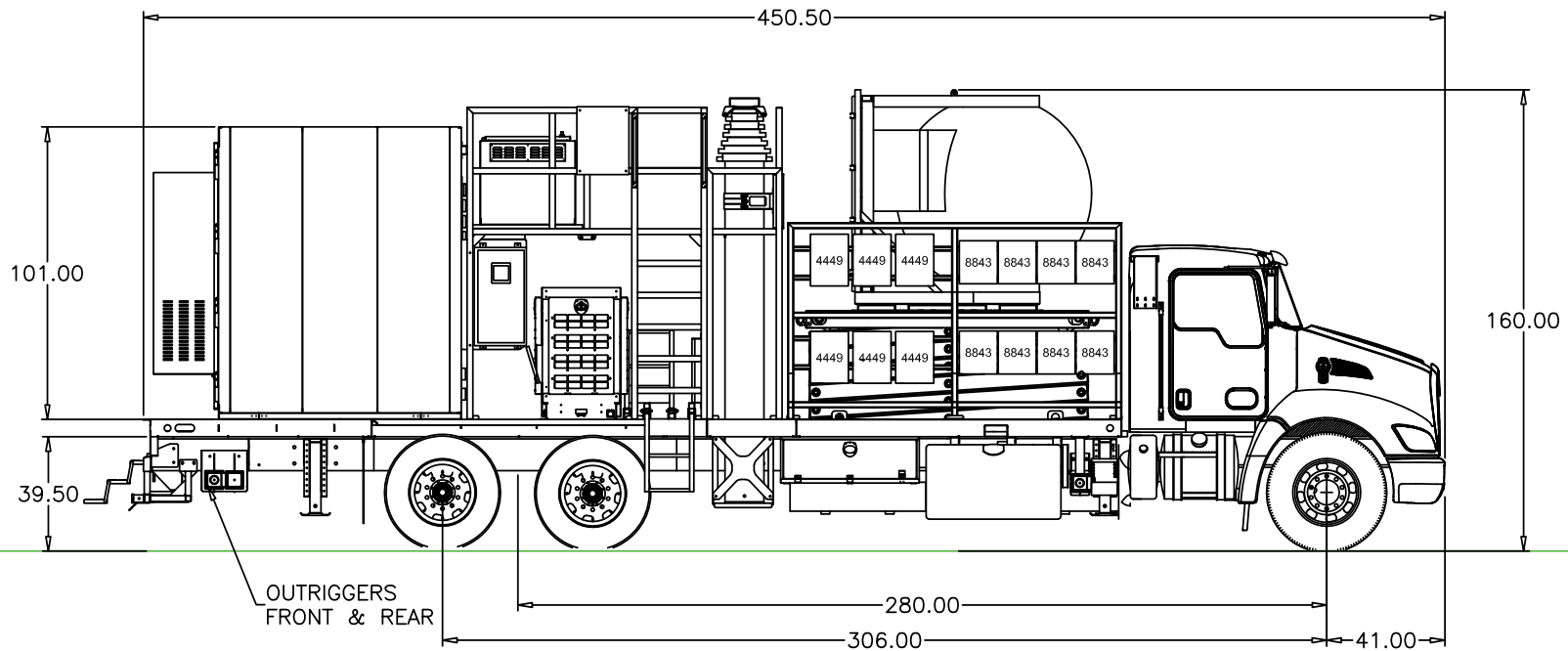
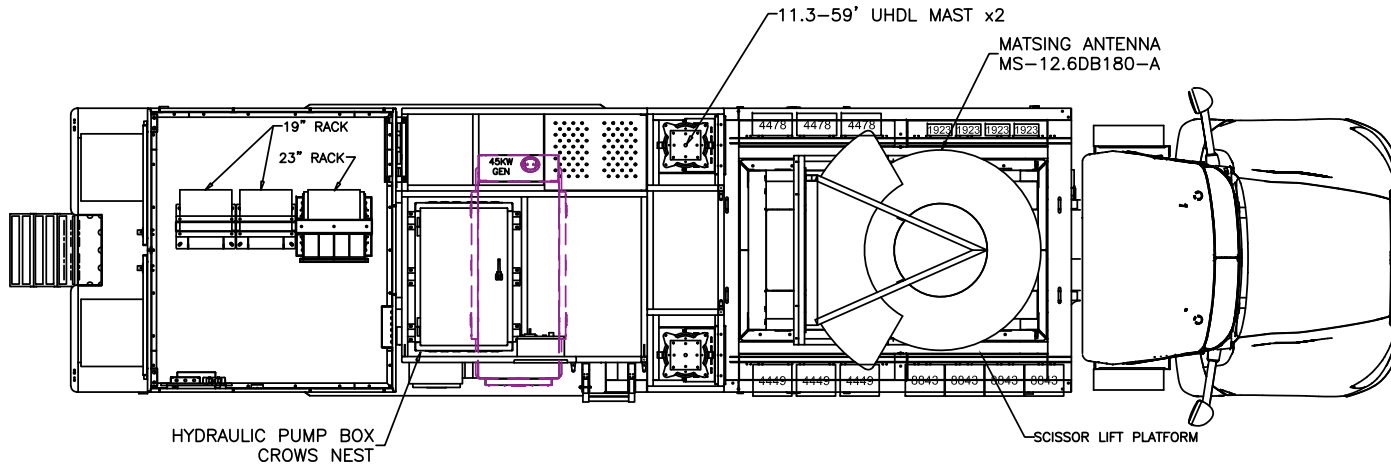

**PROPRIETARY DOCUMENT**

**\*\* PROPRIETARY AND CONFIDENTIAL \*\***  
 Copyright © 2020 & Present Sun West Engineering, Inc.  
 THIS DOCUMENT CONTAINS TRADE SECRETS AND  
 OTHER PROPRIETARY AND CONFIDENTIAL  
 INFORMATION OF SUN WEST ENGINEERING, INC.  
 THIS DOCUMENT AND ITS CONTENTS, INCLUDING  
 WITHOUT LIMITATION THE DRAWING AND OTHER  
 INFORMATION HEREIN, ARE THE SOLE AND EXCLUSIVE  
 PROPERTY OF SUN WEST ENGINEERING, INC.  
 ANY DUPLICATION, DISCLOSURE OR USE OF ANY  
 PORTION OF THIS DOCUMENT REQUIRES THE PRIOR  
 WRITTEN CONSENT OF SUN WEST ENGINEERING, INC.



<b>SUN WEST ENGINEERING, INC.</b> 3802 E. BROADWAY, PHOENIX, AZ 85040 (602) 275-0882	
TITLE: COLT w/ SCISSOR LIFT, (2) 59' MASTS & 45KW GEN.	
CUSTOMER:	
PLOT SCALE: .XXXX=1	SHEET: 1 of 1
DRAWN BY: <i>EMC</i>	DATE: 10/9/20
REVISED:	DWG. SW-5954-A